

Schrumpffutter zum Spannen von HM und HSS Werkzeugschäften

Shrink chucks for mounting of solid carbide and HSS-tool shanks

Mandrins de frettage pour le serrage de queues d'outils carbures de type HM et HSS

JIS B 6339



Verwendung:
Zur Aufnahme von Werkzeugen mit
Zylinderschaft.

Application:
For mounting straight-shank tools.

Application:
Pour le serrage d'outils avec queue
cylindrique.

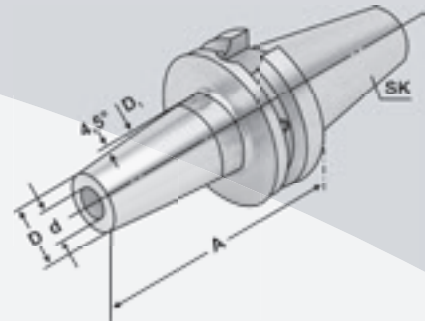

JIS B 6339



$\nearrow \leq 0,003$

G2,5
25.000 min⁻¹

CAD

Bestell-Nr. Order no. Référence	SK	d	A	D	D ₁	l ₁	l ₂
305.70.03 *	BT 30	3	80	11	15	10	–
305.70.04 *	BT 30	4	80	14	22	20	5
305.70.05 *	BT 30	5	80	16	22	20	5
305.70.06 *	BT 30	6	80	21	27	36	10
305.70.08 *	BT 30	8	80	21	27	36	10
305.70.10 *	BT 30	10	90	24	32	42	10
305.70.12 *	BT 30	12	90	24	32	47	10
305.70.14 *	BT 30	14	90	27	34	47	10
305.70.16 *	BT 30	16	90	27	34	50	10
305.70.18 *	BT 30	18	90	33	42	50	10
305.70.20 *	BT 30	20	90	33	42	52	10
406.70.03	BT 40	3	80	11	15	10	–
406.70.04	BT 40	4	80	14	22	20	5
406.70.05	BT 40	5	80	16	22	20	5
406.70.06	BT 40	6	90	21	27	36	10
406.70.08	BT 40	8	90	21	27	36	10
406.70.10	BT 40	10	90	24	32	41	10
406.70.12	BT 40	12	90	24	32	47	10
406.70.14	BT 40	14	90	27	34	47	10
406.70.16	BT 40	16	90	27	34	50	10
406.70.18	BT 40	18	90	33	42	50	10
406.70.20	BT 40	20	90	33	42	52	10
406.70.25	BT 40	25	100	44	53	58	10
406.70.32	BT 40	32	100	44	53	58	10

* JIS B 6339 Form AD

* JIS B 6339 form AD

* JIS B 6339 forme AD

Für Ø 3, 4 und 5 mm nur Hartmetallschäfte verwenden!

For Ø 3, 4 and 5 mm only solid carbide tool shanks must be used!

Pour Ø 3, 4 et 5 mm il faut seulement utiliser de queues d'outils carbures de type HM!

Hinweis: Aufnahme für Induktiv-, Kontakt- und Heißluftschumpfergeräte geeignet.
Schafttoleranz bei Ø 3, 4 und 5 mm = h₄, bei Ø 6 – Ø 32 mm = h₆

Note: Toolholders suitable for induction-, contact- and hot air shrink units.
Ø 3, 4, 5 with h₄-tolerance and Ø 6 – Ø 32 with h₆-tolerance

Observation: Porte-outils convenables pour machines à fretter par induction-,
par contact-, ou par air chaud.
Ø 3, 4, 5 avec h₄-tolerance et Ø 6 – Ø 32 avec h₆-tolerance

l₁ = max. Einstecktiefe
l₁ = max. clamping depth
l₁ = max. profondeur d'insertion

l₂ = max. Verstellweg
l₂ = max. length adjustment range
l₂ = max. course de réglage

